

- WALL/KILN SPACING:** 12" [30.5cm] SPACING BETWEEN SIDES OF KILN AND WALLS OR OTHER OBJECTS. 18" [45.7cm] IS RECOMMENDED. LEAVE AT LEAST 18" [45.7cm] BETWEEN TWO KILNS.
- AMBIENT VENTILATION:** SEE CHART TO RIGHT FOR RATINGS. TO CALCULATE REQUIREMENTS, SEE hotkilns.com/calculate-kiln-room-ventilation.
- KILN VENTILATION:** L&L VENT-SURE KILN VENT RECOMMENDED FOR SAFETY AND LONGER ELEMENT LIFE. OPTIONAL CONTROL ALLOWS VENT TO BE TURNED ON AND OFF WITH CONTROL.

- OTHER INFO:** REFER TO INSTALLATION INSTRUCTIONS AND CAUTIONS INSTRUCTIONS FOR OTHER REQUIREMENTS AND SAFETY INFORMATION. REFER TO WIRING DIAGRAM FOR ELECTRICAL HOOKUP INFORMATION.
- MAX LOAD WEIGHT:** SEE hotkilns.com/load-weight.
- WEIGHT OF KILN:** 455 LBS, 206 KG

BTUS/ KILOJOULES PER HOUR NEEDED TO BE VENTED WITH AMBIENT ROOM VENTILATION (THIS IS IN ADDITION TO KILN VENTING):			
AT TEMP F	BTUS	AT TEMP C	KILOJOULES
1800F	10714	980C	11304
2000F	12526	1095C	13215
2232F	14790	1222C	15604
2350F	16008	1285C	16889

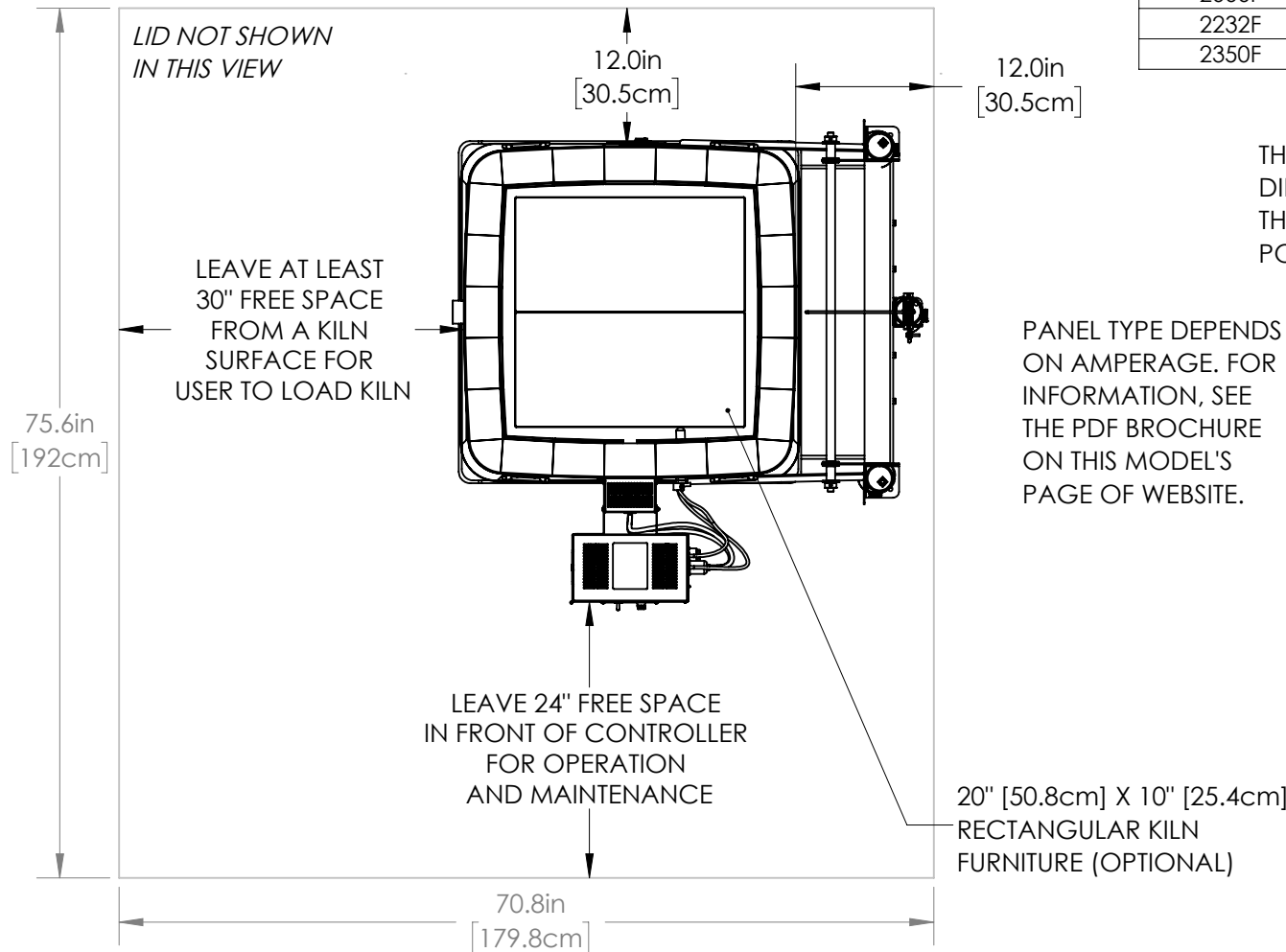

THIS MODEL IS DIRECT WIRED. THERE IS NO POWER CORD.

PANEL TYPE DEPENDS ON AMPERAGE. FOR INFORMATION, SEE THE PDF BROCHURE ON THIS MODEL'S PAGE OF WEBSITE.

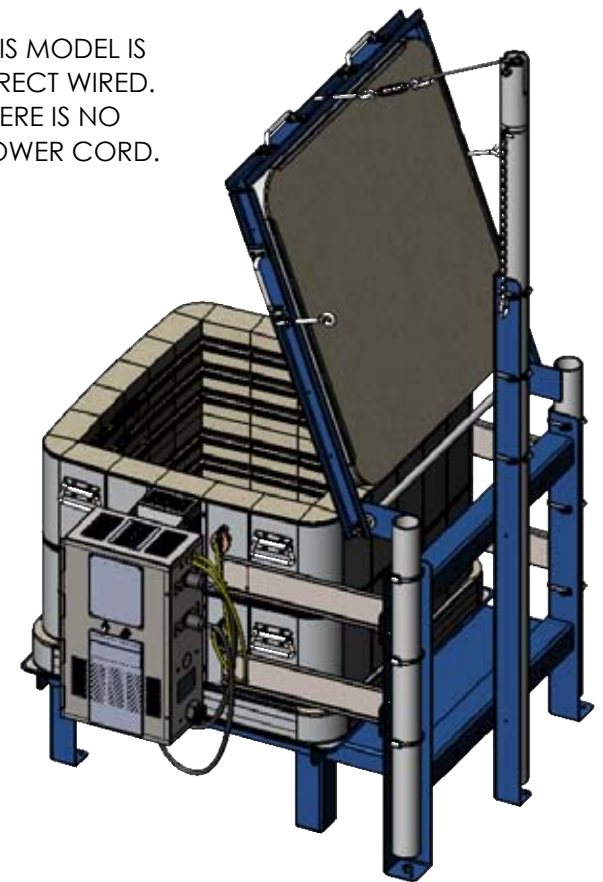

LID NOT SHOWN
IN THIS VIEW

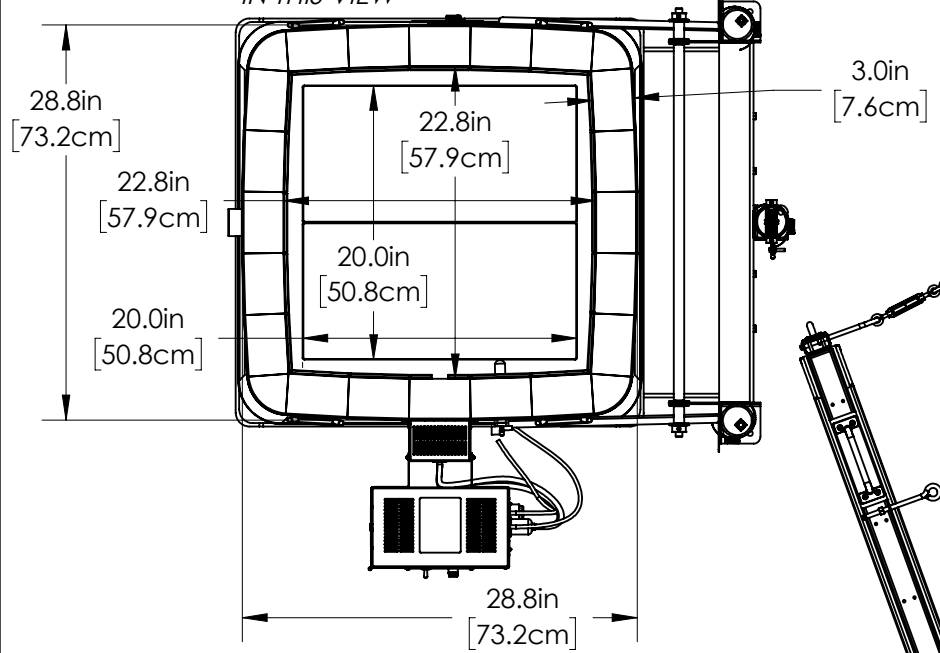

EXPANDABILITY: THIS MODEL CAN BE EXPANDED TO AN X2327 BY ADDING ONE SECTION AND ADDING CORRESPONDING CIRCUITS IN THE CONTROL PANEL.

NOTE: JUPITER CONTROL PANEL IS SHOWN. NEMA 1 PANEL OPTION IS LARGER

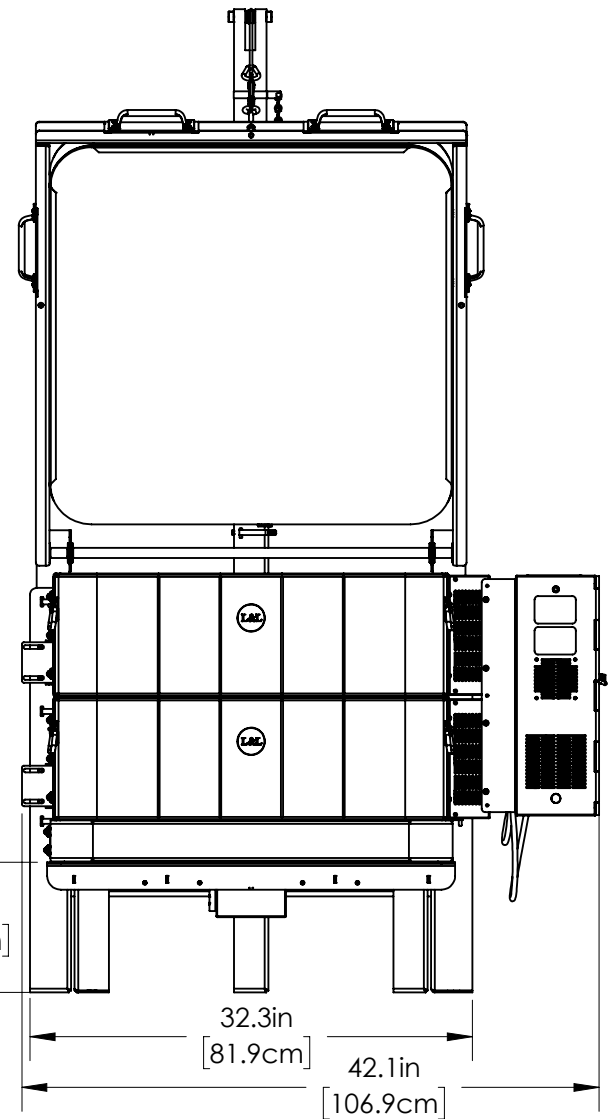
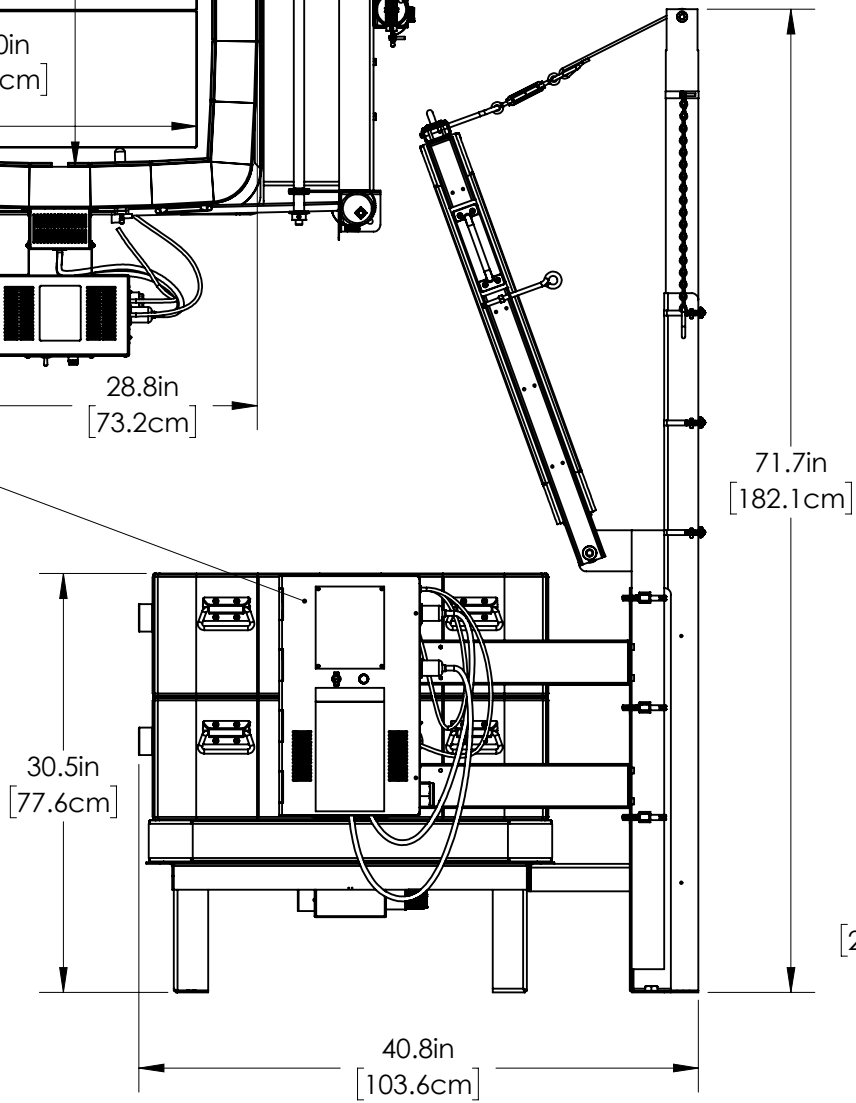

DRAWN BY SJL	DATE 04/15/20	SCALE 1:14	TITLE XB2318-D (3" BRICK) DAVINCI GENERAL DIMENSIONS	505 SHARPTOWN RD SWEDESBORO NJ 08085 PH: (856) 294-0077 FAX: (856) 294-0070	REV 0	SHEET OF 2/3	DRAWING NO. 300-000-20-2
-----------------	------------------	---------------	---	--	----------	-----------------	-----------------------------

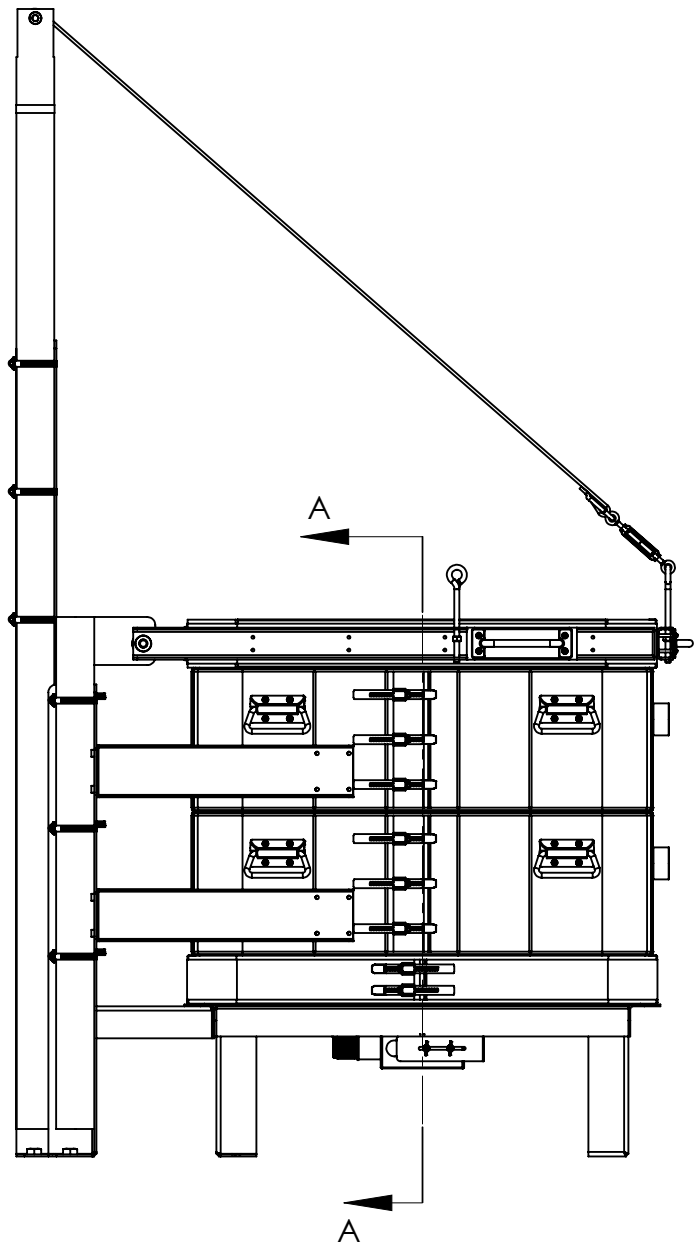

SECTION A-A

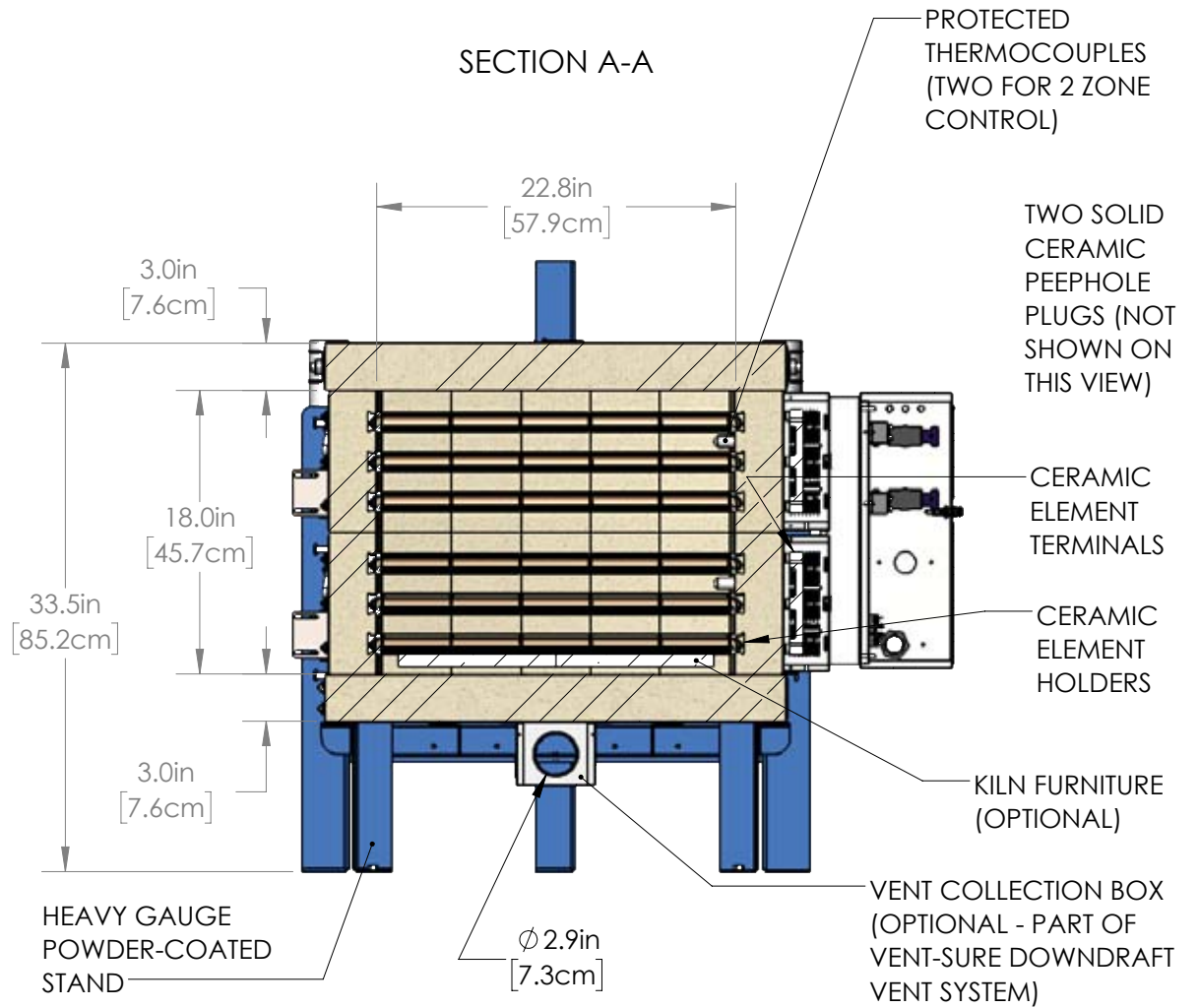

OPTIONAL FURNITURE KIT: (4) 20" [50.8cm] X 10" [25.4cm] RECTANGULAR SHELVES, (6) EACH 1/2", 1", 2", 4", 6" & 8" SQUARE POSTS

DRAWN BY SJL	DATE 04/15/20	SCALE 1:12	TITLE XB2318-D (3" BRICK) DAVINCI GENERAL DIMENSIONS	LKilns hotkilns.com	505 SHARPTOWN RD SWEDESBORO NJ 08085 PH: (856) 294-0077 FAX: (856) 294-0070	REV 0	SHEET OF 3/3	DRAWING NO. 300-000-20-2
-----------------	------------------	---------------	---	-------------------------------	--	-----------------	-----------------	-----------------------------