

- WALL/KILN SPACING:** 12" [30.5cm] SPACING BETWEEN SIDES OF KILN AND WALLS OR OTHER OBJECTS. 18" [45.7cm] IS RECOMMENDED. LEAVE AT LEAST 18" [45.7cm] BETWEEN TWO KILNS.
- AMBIENT VENTILATION:** SEE CHART TO RIGHT FOR RATINGS. TO CALCULATE REQUIREMENTS, SEE [hotkilns.com/calculate-kiln-room-ventilation](http://hotkilns.com/calculate-kiln-room-ventilation).
- KILN VENTILATION:** L&L VENT-SURE KILN VENT RECOMMENDED FOR SAFETY AND LONGER ELEMENT LIFE. OPTIONAL CONTROL ALLOWS VENT TO BE TURNED ON AND OFF WITH CONTROL.

- OTHER INFO:** REFER TO INSTALLATION INSTRUCTIONS AND CAUTIONS INSTRUCTIONS FOR OTHER REQUIREMENTS AND SAFETY INFORMATION. REFER TO WIRING DIAGRAM FOR ELECTRICAL HOOKUP INFORMATION.
- MAX LOAD WEIGHT:** SEE [hotkilns.com/load-weight](http://hotkilns.com/load-weight).
- WEIGHT OF KILN:** 590 LBS, 268 KG

BTUS/ KILOJOULES PER HOUR NEEDED TO BE VENTED WITH AMBIENT ROOM VENTILATION (THIS IS IN ADDITION TO KILN VENTING):

AT TEMP F	BTUS	AT TEMP C	KILOJOULES
1800F	22497	980C	23735
2000F	26298	1095C	27746
2232F	31050	1222C	32760
2350F	33606	1285C	35456

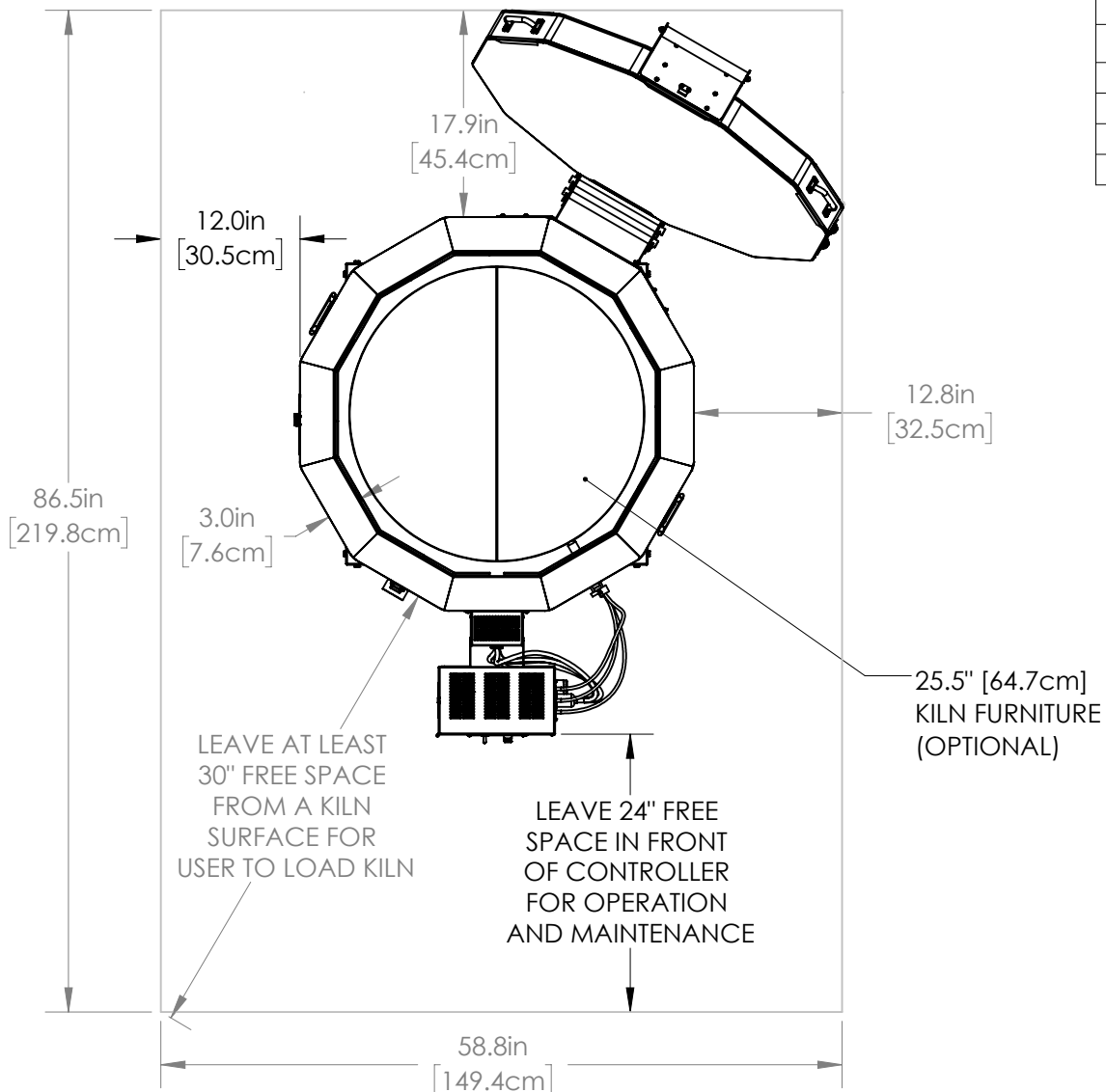

THIS MODEL IS DIRECT WIRED. THERE IS NO POWER CORD.

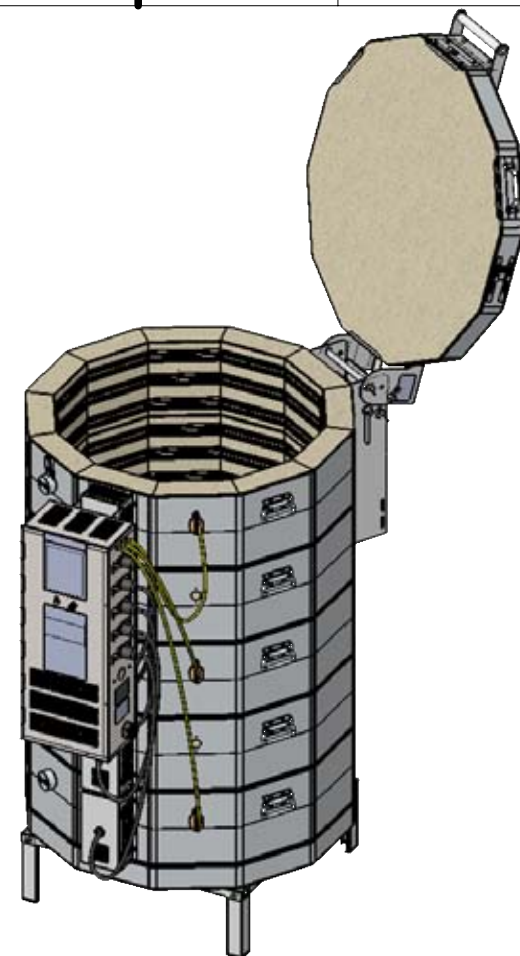

MADE FROM NEW  
 DRAWN BY DSL  
 DATE 02/01/20  
 SCALE 1:16  
 TITLE JD2945-3 (3" BRICK) GENERAL DIMENSIONS



505 SHARPTOWN RD  
 SWEDESBORO NJ 08085  
 PH: (856) 294-0077  
 FAX: (856) 294-0070

REV 0  
 SHEET OF 1/3  
 DRAWING NO. 235-000-60-5

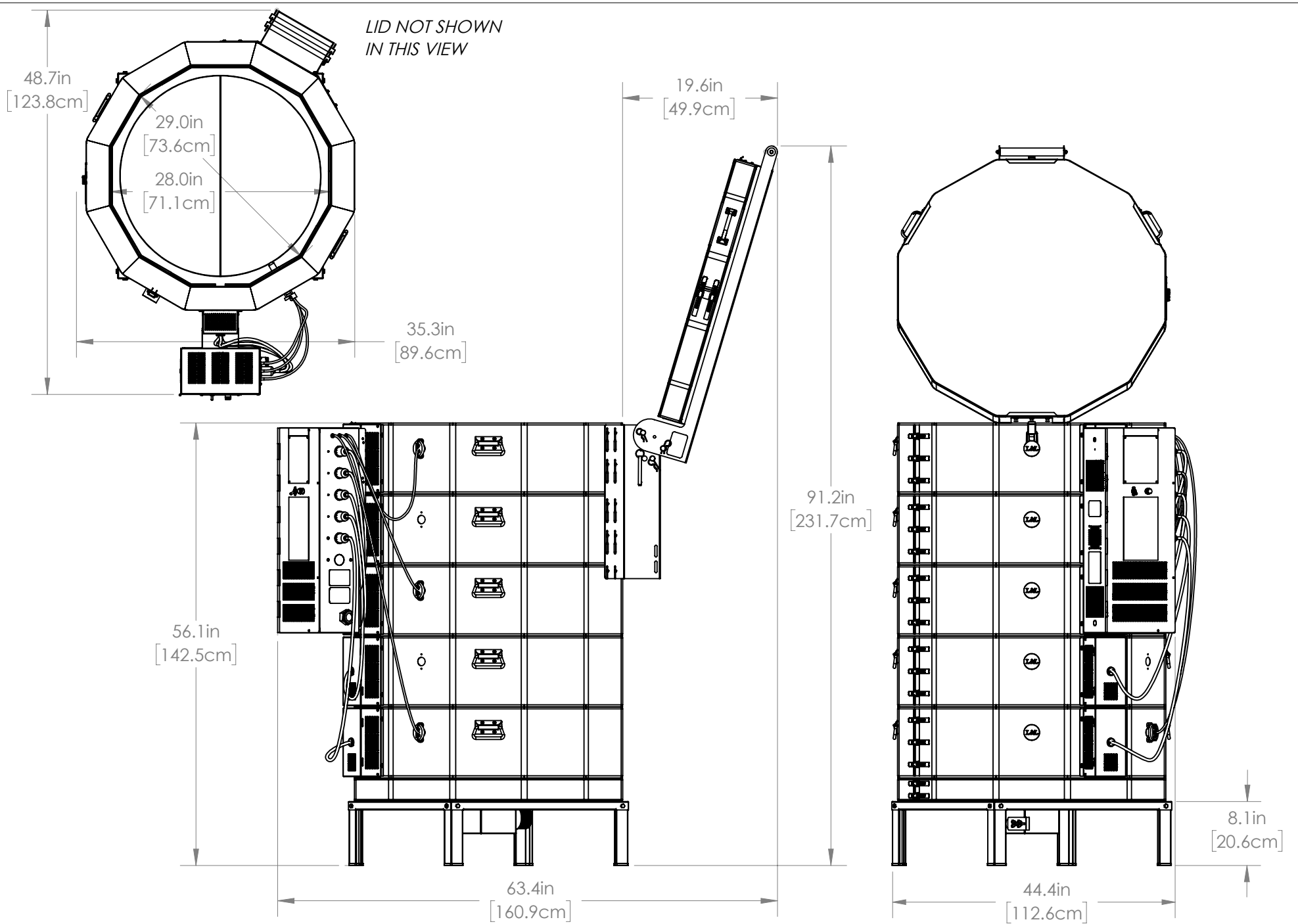

MADE FROM  
NEW

DRAWN BY  
DSL

DATE  
02/01/20

SCALE  
1:16

TITLE  
JD2945-3 (3" BRICK) GENERAL DIMENSIONS

**LKilns**  
hotkilns.com

505 SHARPTOWN RD  
SWEDESBORO NJ 08085  
PH: (856) 294-0077  
FAX: (856) 294-0070

REV  
0

SHEET OF  
2/3

DRAWING NO.  
235-000-60-5

5

4

3

2

1

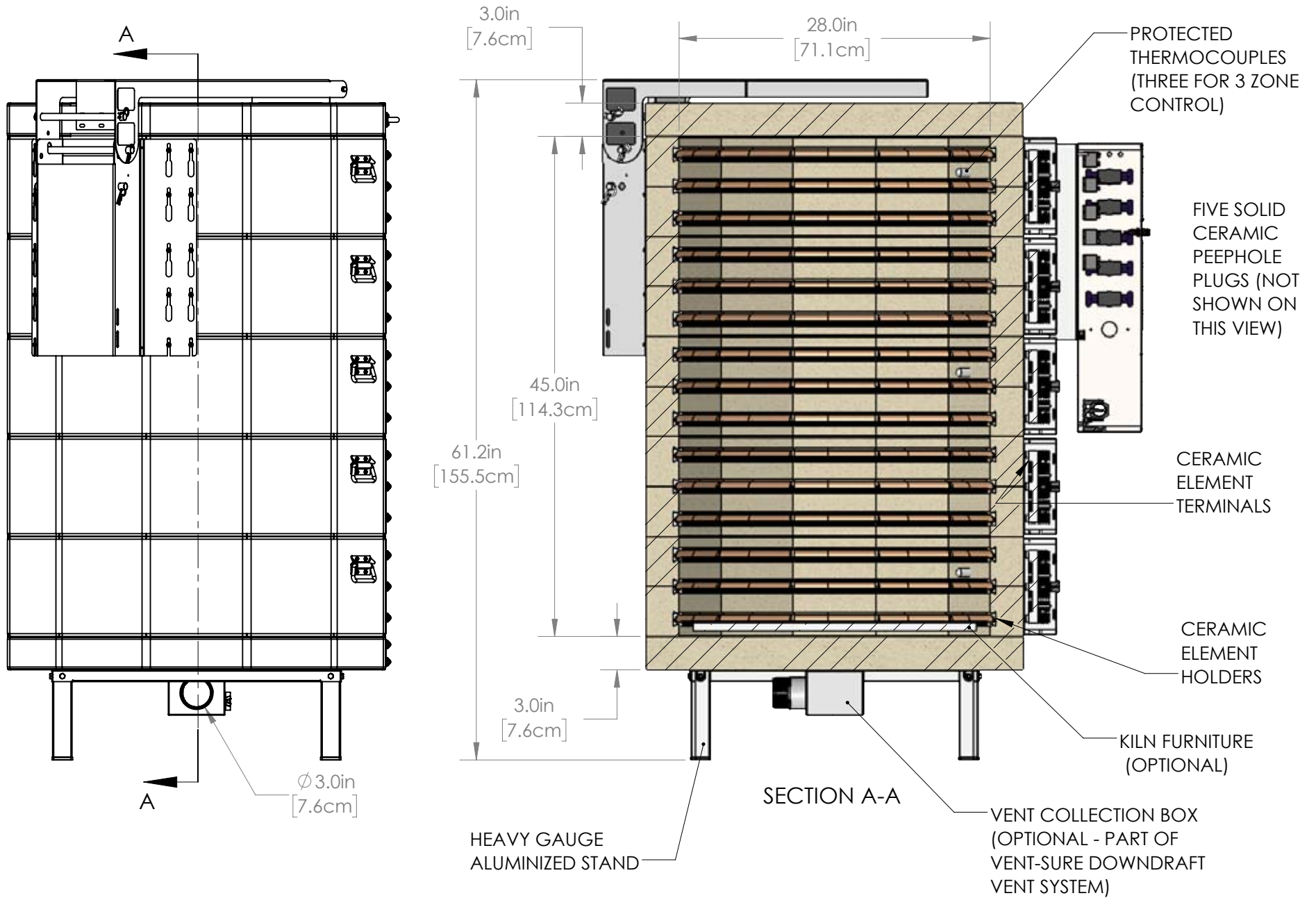

OPTIONAL FURNITURE KIT: (12) 25.5" [64.7cm] HALF ROUND SHELVES, SIX EACH 1/2", 1", 2", 4", 6" & 8" SQUARE POSTS

MADE FROM 0	DRAWN BY DSL	DATE 02/01/20	SCALE 1:12	TITLE JD2945-3 (3" BRICK) GENERAL DIMENSIONS	<b>LKilns</b> hotkilns.com	505 SHARPTOWN RD SWEDESBORO NJ 08085 PH: (856) 294-0077 FAX: (856) 294-0070	REV 0	SHEET OF 3/3	DRAWING NO. 235-000-60-5
----------------	-----------------	------------------	---------------	---	-------------------------------	--	----------	-----------------	-----------------------------