

- 1. WALL/KILN SPACING:** 12" [30.5cm] SPACING BETWEEN SIDES OF KILN AND WALLS OR OTHER OBJECTS. 18" [45.7cm] IS RECOMMENDED. LEAVE AT LEAST 18" [45.7cm] BETWEEN TWO KILNS.
- 2. AMBIENT VENTILATION:** SEE CHART TO RIGHT FOR RATINGS. TO CALCULATE REQUIREMENTS, SEE hotkilns.com/calculate-kiln-room-ventilation.
- 3. KILN VENTILATION:** L&L VENT-SURE KILN VENT RECOMMENDED FOR SAFETY AND LONGER ELEMENT LIFE. OPTIONAL CONTROL ALLOWS VENT TO BE TURNED ON AND OFF WITH CONTROL.

- 4. OTHER INFO:** REFER TO INSTALLATION INSTRUCTIONS AND CAUTIONS INSTRUCTIONS FOR OTHER REQUIREMENTS AND SAFETY INFORMATION. REFER TO WIRING DIAGRAM FOR ELECTRICAL HOOKUP INFORMATION.
- 5. MAX LOAD WEIGHT:** SEE hotkilns.com/load-weight.
- 6. WEIGHT OF KILN:** 435 LBS, 197 KG

BTUS/ KILOJOULES PER HOUR NEEDED TO BE VENTED WITH AMBIENT ROOM VENTILATION (THIS IS IN ADDITION TO KILN VENTING):			
AT TEMP F	BTUS	AT TEMP C	KILOJOULES
1800F	15614	980C	16474
2000F	18254	1095C	19259
2232F	21554	1222C	22741
2350F	23329	1285C	24613

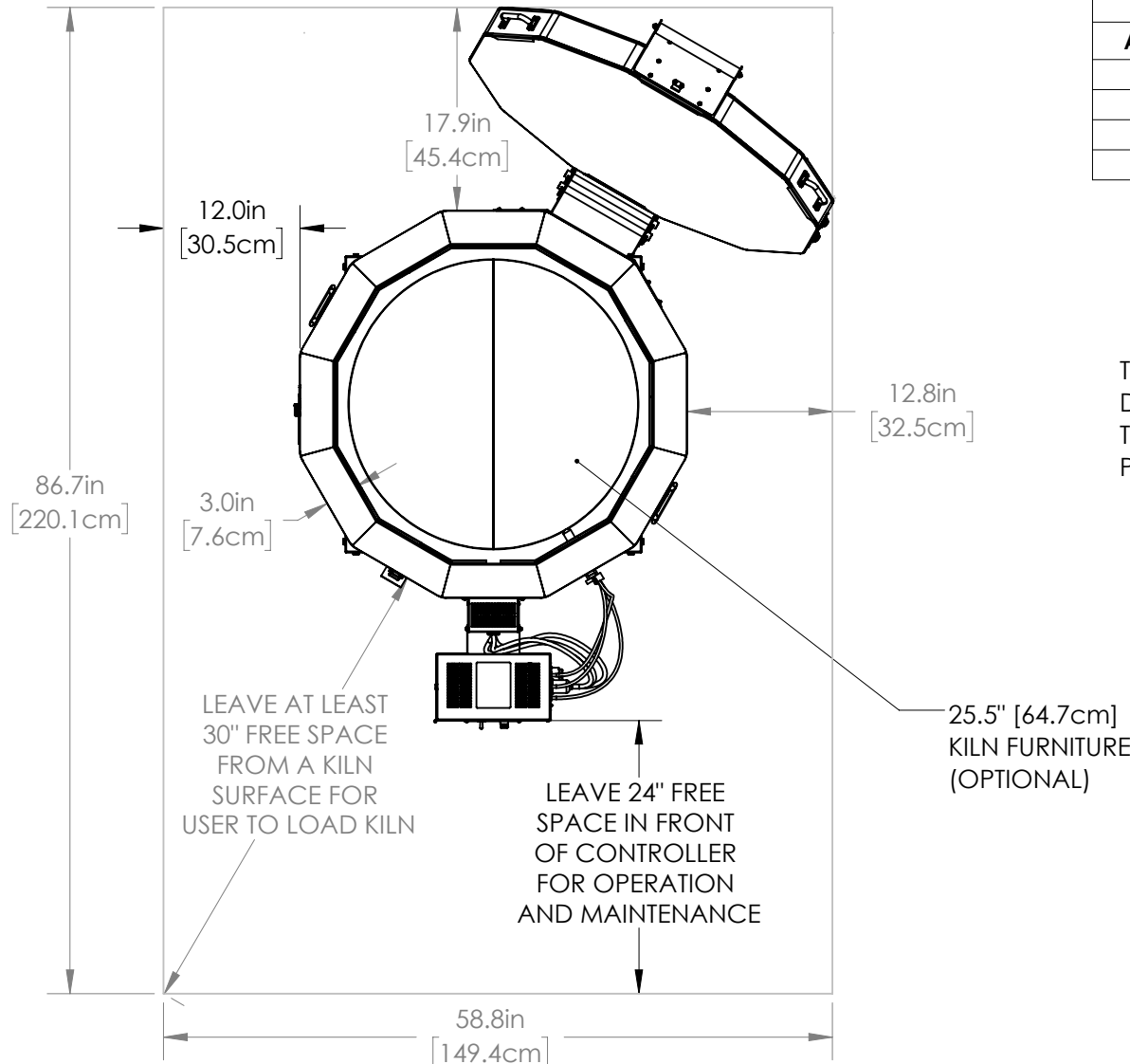

THIS MODEL IS DIRECT WIRED. THERE IS NO POWER CORD.

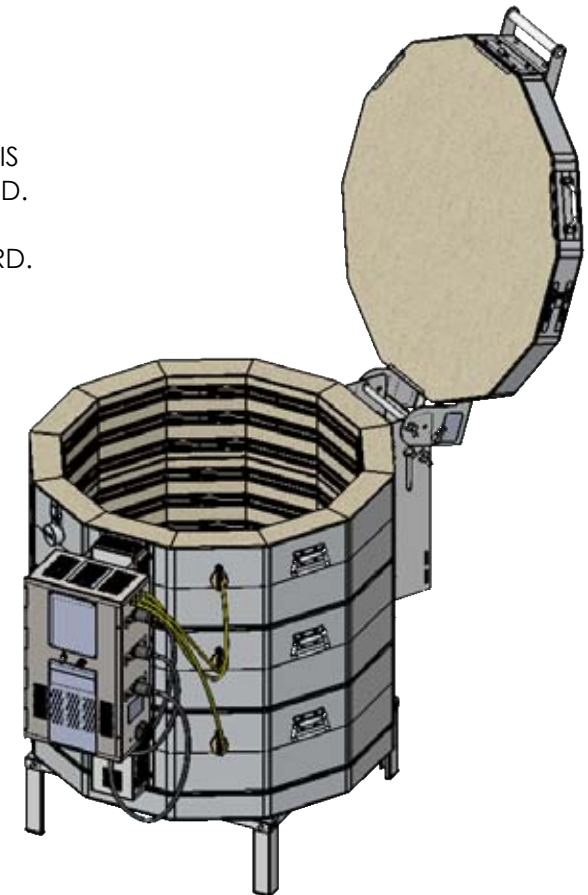

MADE FROM NEW	DRAWN BY DSL	DATE 02/01/20	SCALE 1:16	TITLE JD2927-3 (3" BRICK) GENERAL DIMENSIONS
------------------	-----------------	------------------	---------------	---



505 SHARPTOWN RD
SWEDESBORO NJ 08085
PH: (856) 294-0077
FAX: (856) 294-0070

REV 0	SHEET OF 1/3	DRAWING NO. 235-000-60-3
----------	-----------------	-----------------------------

LID NOT SHOWN
IN THIS VIEW

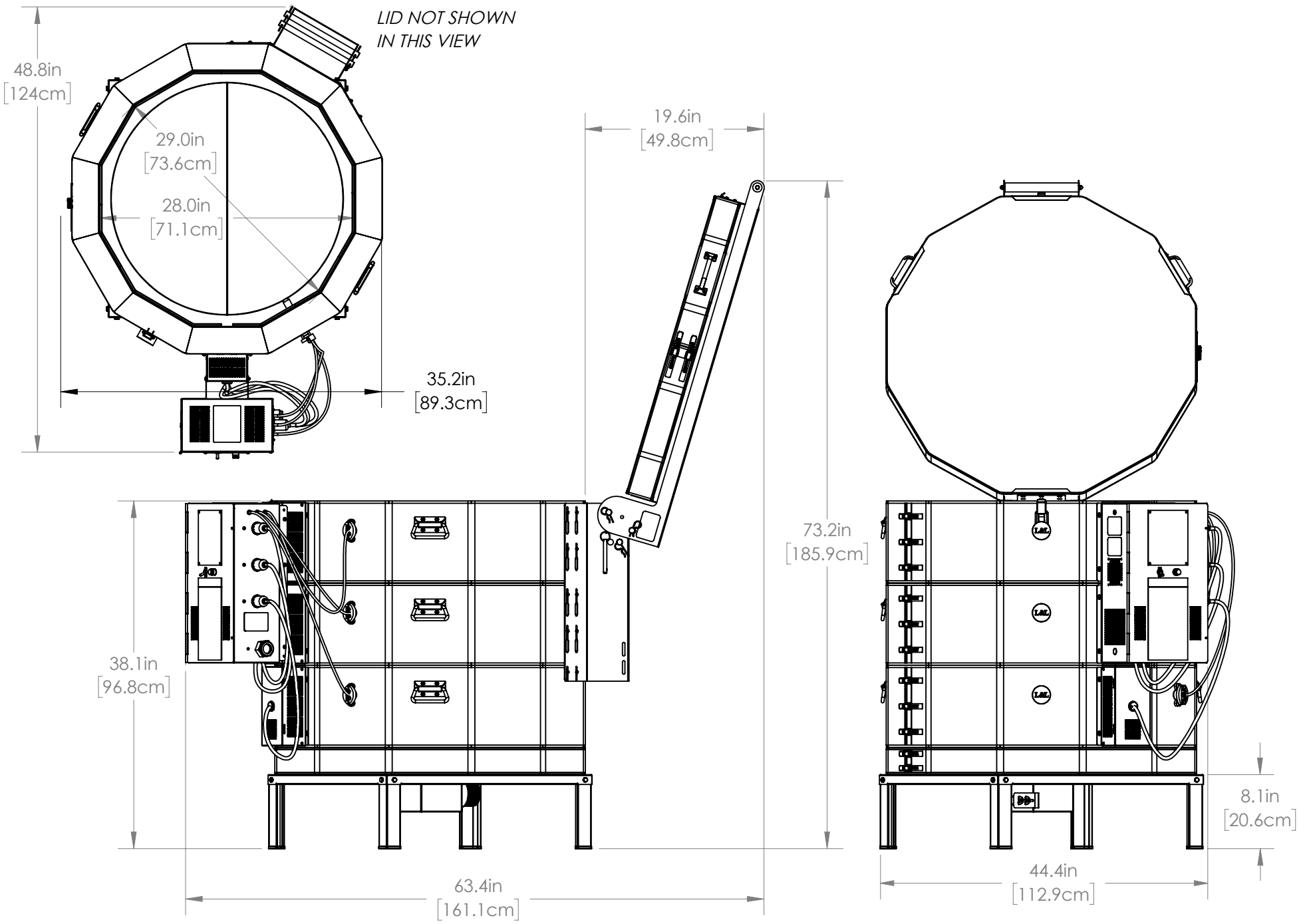

MADE FROM NEW	DRAWN BY DSL	DATE 02/01/20	SCALE 1:14	TITLE JD2927-3 (3" BRICK) GENERAL DIMENSIONS		505 SHARPTOWN RD SWEDESBORO NJ 08085 PH: (856) 294-0077 FAX: (856) 294-0070	REV 0	SHEET OF 2/3	DRAWING NO. 235-000-60-3
------------------	-----------------	------------------	---------------	---	--	--	----------	-----------------	-----------------------------

5 4 3 2 1

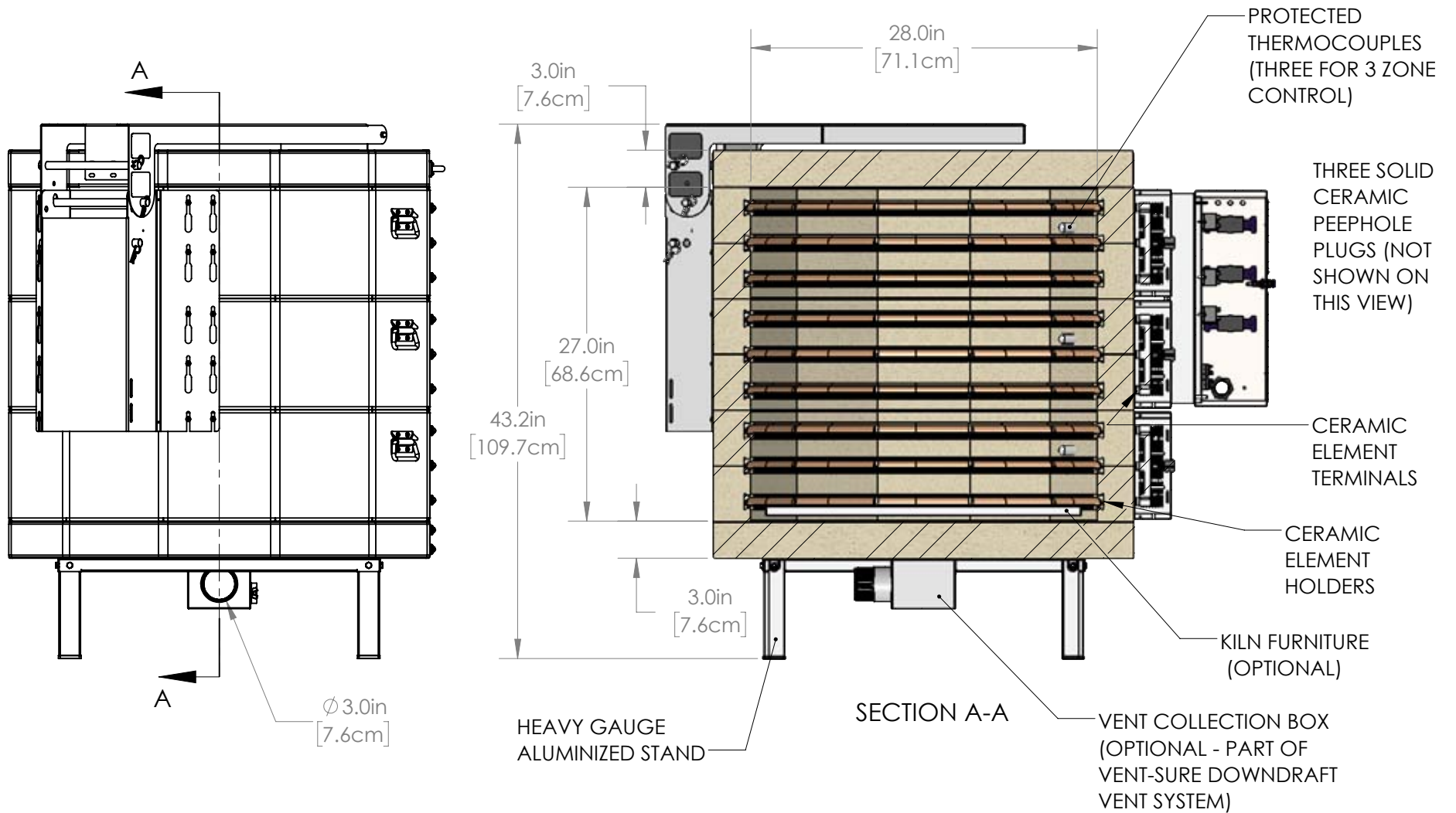

OPTIONAL FURNITURE KIT: (8) 25.5" [64.7cm] HALF ROUND SHELVES, SIX EACH 1/2", 1", 2", 4", 6" & 8" SQUARE POSTS

MADE FROM NEW	DRAWN BY DSL	DATE 02/01/20	SCALE 1:12	TITLE JD2927-3 (3" BRICK) GENERAL DIMENSIONS		505 SHARPTOWN RD SWEDESBORO NJ 08085 PH: (856) 294-0077 FAX: (856) 294-0070	REV 0	SHEET OF 3/3	DRAWING NO. 235-000-60-3
------------------	-----------------	------------------	---------------	---	---	--	----------	-----------------	-----------------------------