

- WALL/KILN SPACING:** 12" [30.5cm] SPACING BETWEEN SIDES OF KILN AND WALLS OR OTHER OBJECTS. 18" [45.7cm] IS RECOMMENDED. LEAVE AT LEAST 18" [45.7cm] BETWEEN TWO KILNS.
- AMBIENT VENTILATION:** SEE CHART TO RIGHT FOR RATINGS. TO CALCULATE REQUIREMENTS, SEE hotkilns.com/calculate-kiln-room-ventilation.
- KILN VENTILATION:** L&L VENT-SURE KILN VENT RECOMMENDED FOR SAFETY AND LONGER ELEMENT LIFE. OPTIONAL CONTROL ALLOWS VENT TO BE TURNED ON AND OFF WITH CONTROL.

- OTHER INFO:** REFER TO INSTALLATION INSTRUCTIONS AND CAUTIONS INSTRUCTIONS FOR OTHER REQUIREMENTS AND SAFETY INFORMATION. REFER TO WIRING DIAGRAM FOR ELECTRICAL HOOKUP INFORMATION.
- MAX LOAD WEIGHT:** SEE hotkilns.com/load-weight.
- WEIGHT OF KILN:** 320 LBS, 146 KG

BTUS/ KILOJOULES PER HOUR NEEDED TO BE VENTED WITH AMBIENT ROOM VENTILATION (THIS IS IN ADDITION TO KILN VENTING):

AT TEMP F	BTUS	AT TEMP C	KILOJOULES
1800F	11667	980C	12309
2000F	13639	1095C	14390
2232F	16104	1222C	16991
2350F	17430	1285C	18390

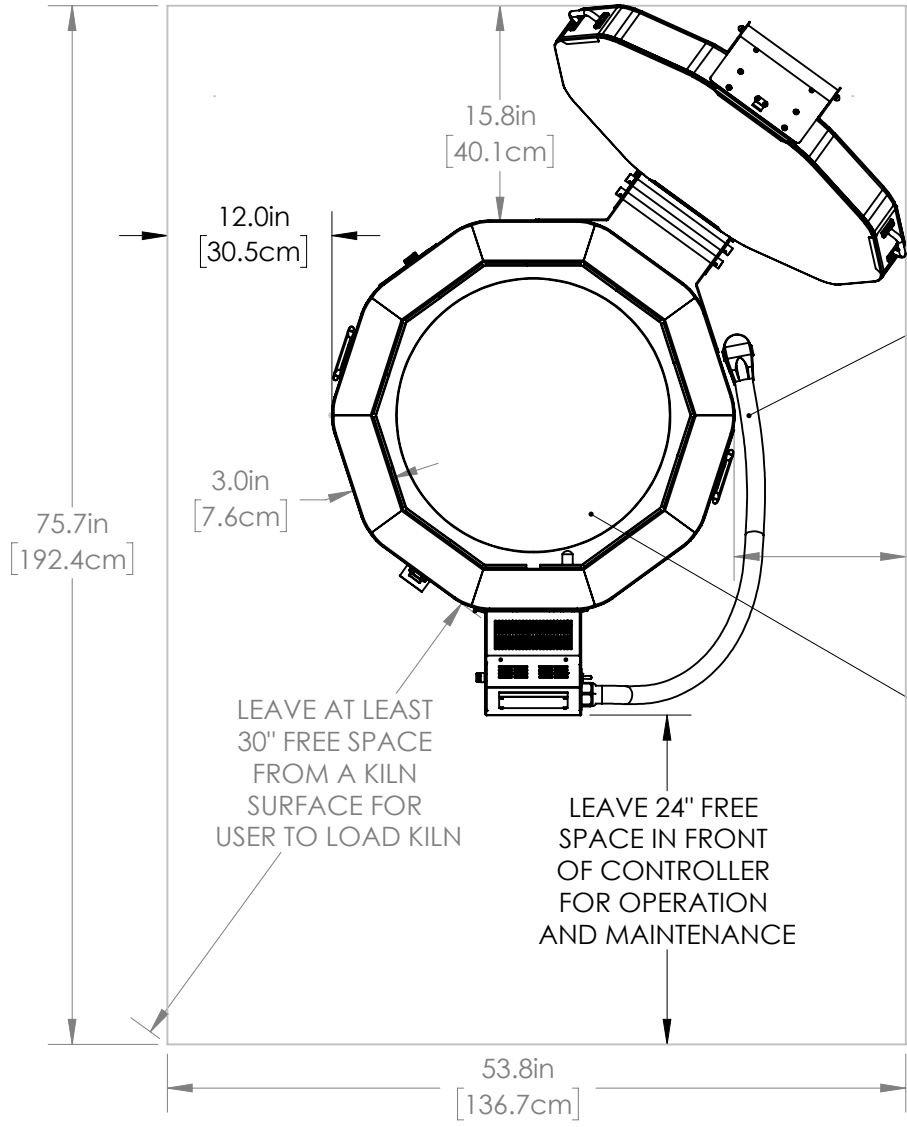

POWER CORD IS 6 FEET LONG: NEMA 6-50 FOR SINGLE PHASE OR 15-50 FOR THREE PHASE. ALTERNATELY KILN MAY BE HARD WIRED TO A FUSED DISCONNECT BOX.

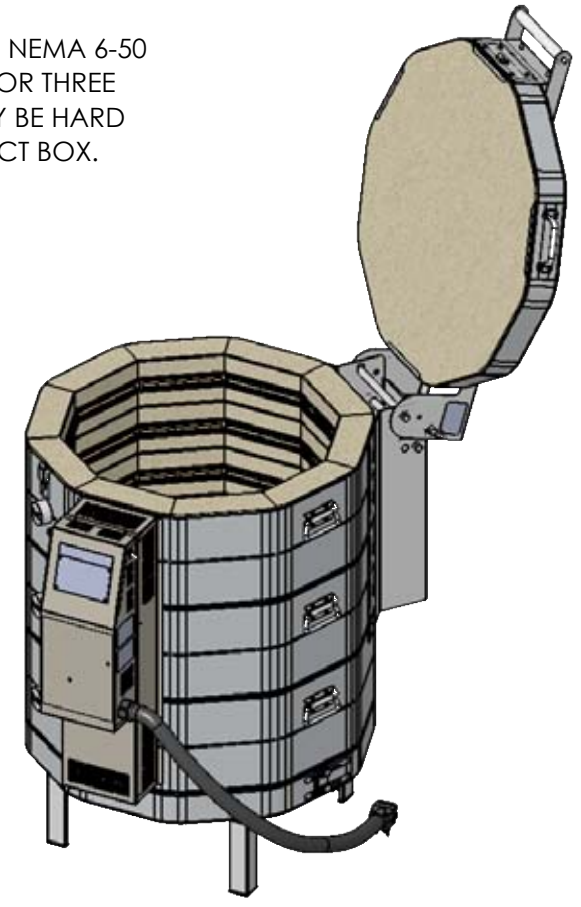

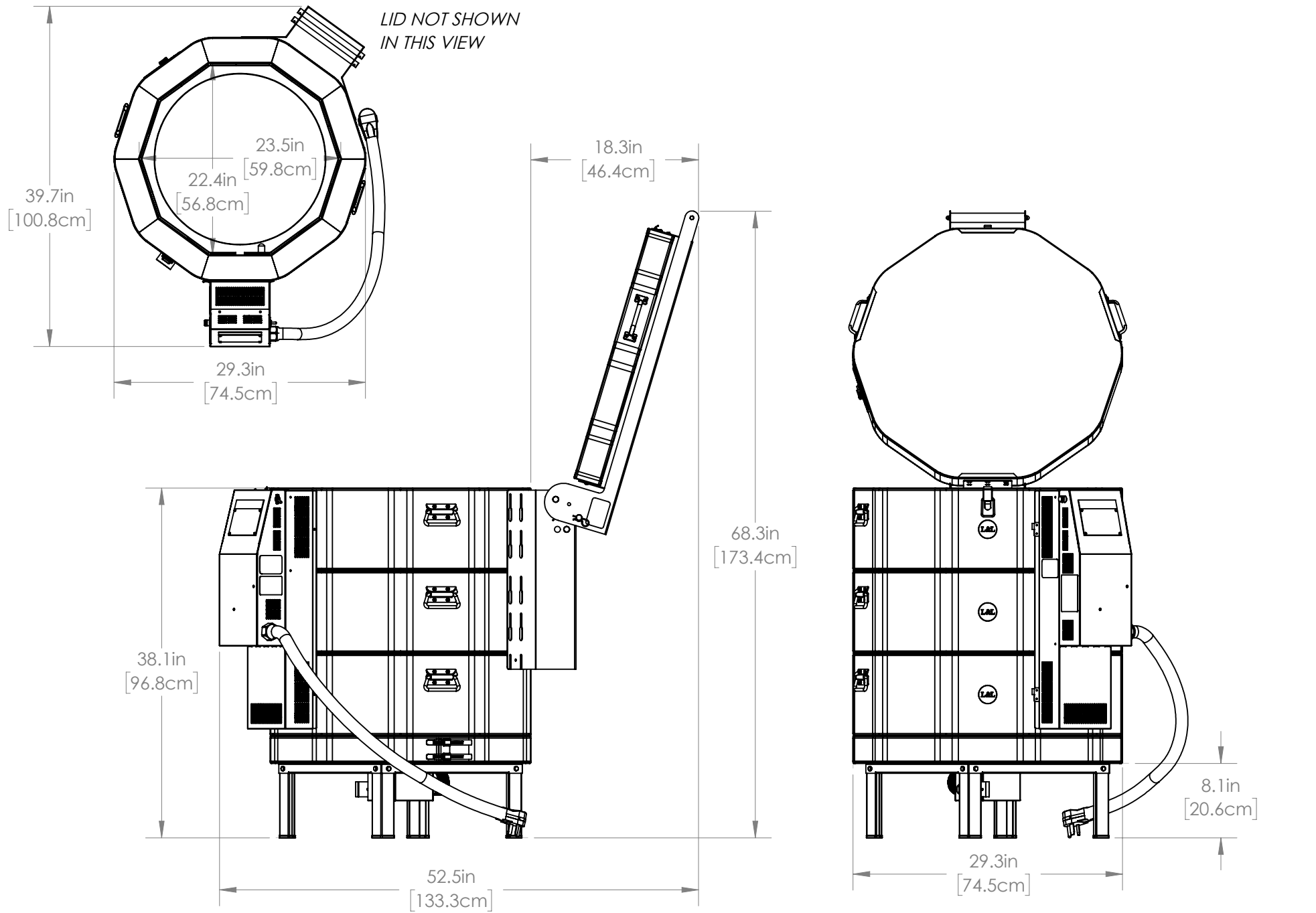

MADE FROM NEW	DRAWN BY SJL	DATE 09/01/19	SCALE 1:14	TITLE SM23T-3 (3" BRICK) GENERAL DIMENSIONS	LKilns hotkilns.com	505 SHARPTOWN RD SWEDESBORO NJ 08085 PH: (856) 294-0077 FAX: (856) 294-0070	REV 0	SHEET OF 2/3	DRAWING NO. 225-000-50-3
------------------	-----------------	------------------	---------------	--	-------------------------------	--	----------	-----------------	-----------------------------

5

4

3

2

1

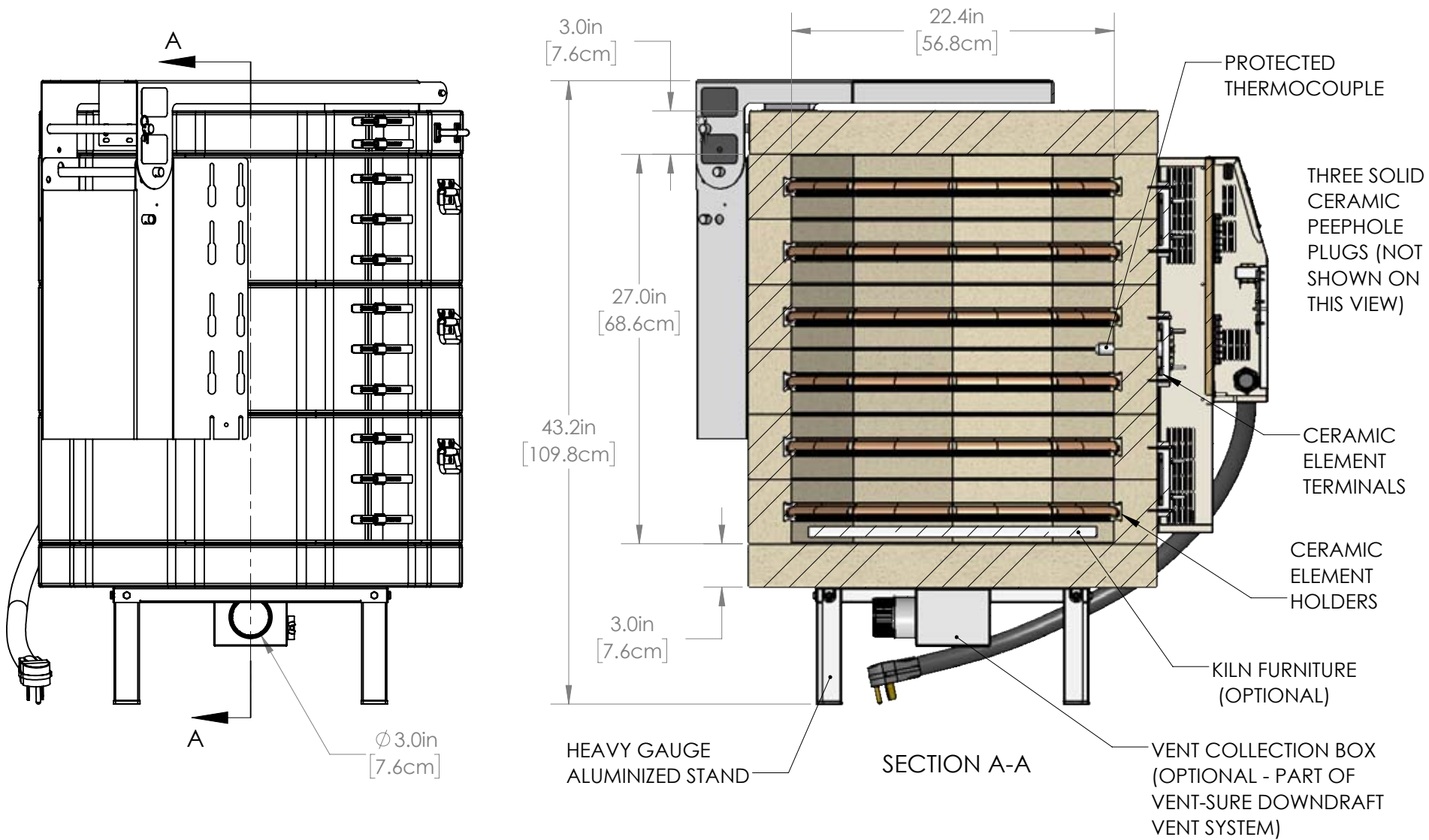

OPTIONAL FURNITURE KIT: (2) 20" [50.8cm] FULL ROUND SHELVES, (4) HALF ROUND SHELVES, SIX EACH 1/2", 1", 2", 4", 6" & 8" SQUARE POSTS

MADE FROM NEW	DRAWN BY SJL	DATE 09/01/19	SCALE 1:10	TITLE SM23T-3 (3" BRICK) GENERAL DIMENSIONS	LKilns hotkilns.com	505 SHARPTOWN RD SWEDESBORO NJ 08085 PH: (856) 294-0077 FAX: (856) 294-0070	REV 0	SHEET OF 3/3	DRAWING NO. 225-000-50-3
------------------	-----------------	------------------	---------------	--	-------------------------------	--	----------	-----------------	-----------------------------