



FOR OVER 50 YEARS... THE KILN TECHNOLOGY LEADER

L&L Kiln Mfg Inc. ♦ 8 Creek Parkway ♦ P.O. Box 1898 ♦ Boothwyn, PA 19061

Phone: (610) 485-1789 ♦ Fax: (610) 485-4665 ♦ Email:sales@hotkilns.com ♦ Web:www.hotkilns.com

JUPITER EASY-LIFT SPRING HINGE SET UP INSTRUCTIONS

CAUTION

There is a great deal of tension created by the torsion spring. Use extreme caution when installing it. Wear safety goggles. Use the special tool provided as directed. The use of a tool that does not grab the end of the spring to allow you to control it may result in serious bodily injury. Call L&L if you do not have this tool. We will provide it at cost for an old kiln.

This is a picture of what you will see when you open the kiln on a J18, J18X, J23, J230, J236, or J245:

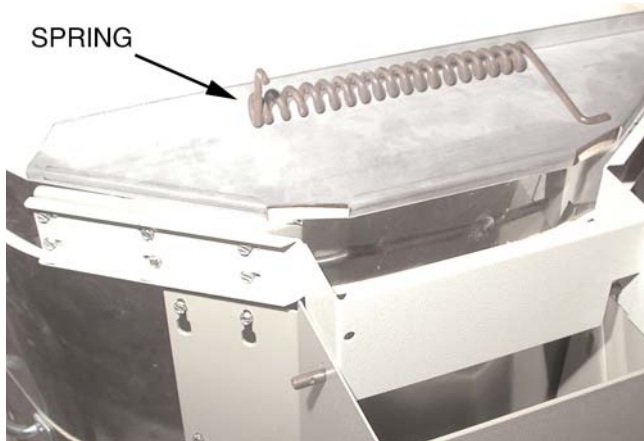

Install hinge bar into hinge while holding spring so that the hinge bar goes through the spring. Note - you will not have to hold the spring on the J2900 kilns because there is a metal trough under where the spring goes:



This is a picture of what you will see when you open the kiln on a J2918, J2927, J2936, or J2945:

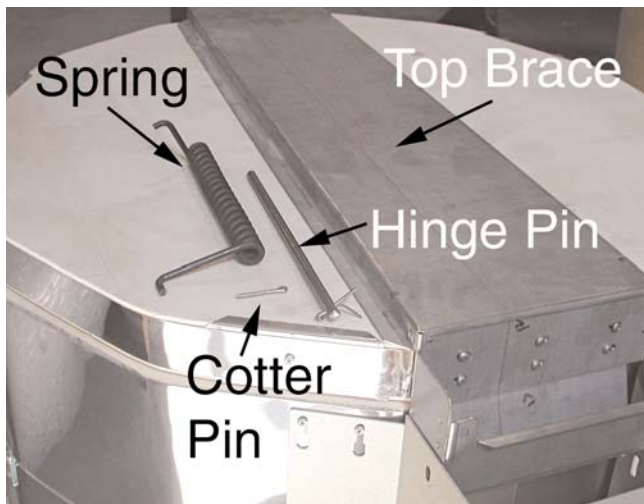

JUPITER EASY-LIFT SPRING HINGE SET UP INSTRUCTIONS

Install cotter pin through hole in end and bend out "wings":



Open lid. This will take most of the tension off the spring and move the end into striking range of the two potential slotted holes that the end must fit into.



Insert special tool through the hole in the back of the hinge box. The slot on the end of the tool will lock onto the spring and allow you to easily maneuver the end of the spring into one of the two slots. Note that there are two slots to allow you to adjust tension on the hinge system.

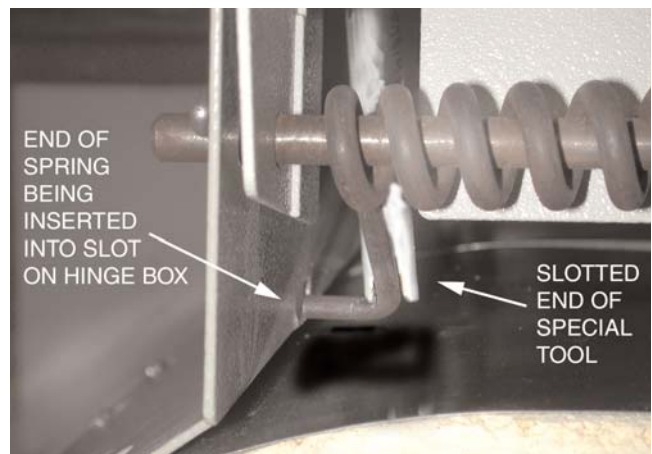
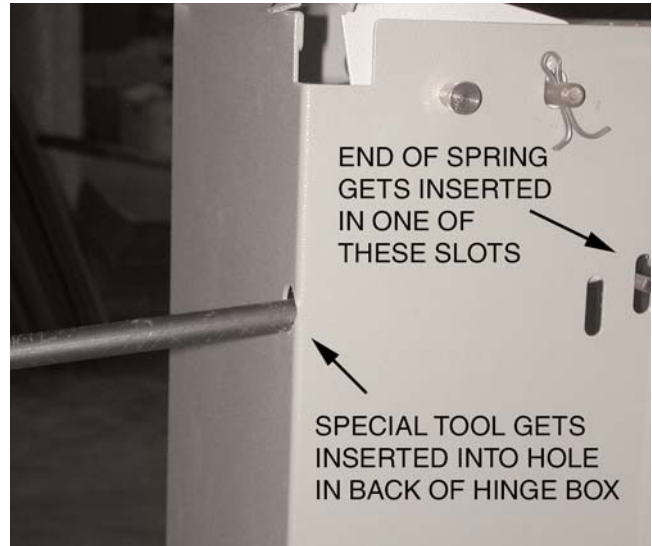

The above is a view from the top looking down into the hinge box. NOTE: When removing the hinge - use the reverse procedure and be sure to use the special tool provided.

JUPITER EASY-LIFT SPRING HINGE SET UP INSTRUCTIONS

In some cases it may be impossible to insert the special tool from the back of the hinge through the hole in the back (because of space clearances). In this case you may use the tool as a lever to move the end of the spring into its slot as shown in the below photographs. This is not the preferred method but is feasible. You must use a 2X4 or other block as a way to move the fulcrum of the level out away from the lid. A 2X4 wood block (as shown) is good because it won't be as abrasive on the soft firebrick of the lid.

